

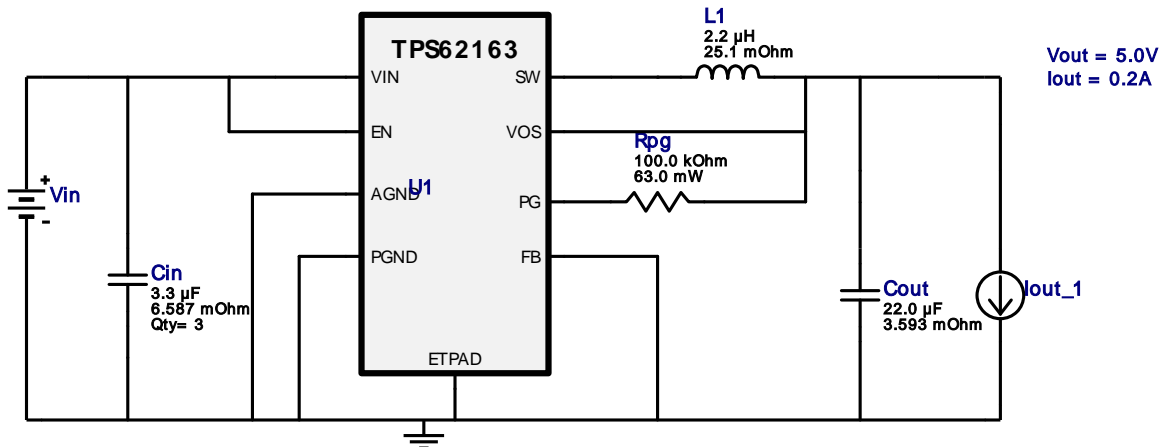





WEBENCH® Design Report

 Design : 2425056/75 TPS62163DSGR
 TPS62163DSGR 6.0V-15.0V to 5.00V @ 0.2A

Electrical BOM

#	Name	Manufacturer	Part Number	Properties	Qty	Price	Footprint
1.	Cin	MuRata	GRM21BR61E335KA12L Series= X5R	Cap= 3.3 uF ESR= 6.587 mOhm VDC= 25.0 V IRMS= 0.0 A	3	\$0.09	 0805 7 mm ²
2.	Cout	MuRata	GRM31CR71A226KE15L Series= X7R	Cap= 22.0 uF ESR= 3.593 mOhm VDC= 10.0 V IRMS= 3.5332 A	1	\$0.12	 1206_190 11 mm ²
3.	L1	Bourns	SRN6045-2R2Y	L= 2.2 µH DCR= 25.1 mOhm	1	\$0.16	 SRN6045 64 mm ²
4.	Rpg	Vishay-Dale	CRCW0402100KFKED Series= CRCW...e3	Res= 100.0 kOhm Power= 63.0 mW Tolerance= 1.0%	1	\$0.01	 0402 3 mm ²
5.	U1	Texas Instruments	TPS62163DSGR	Switcher	1	\$0.73	 S-PWSON-N8 10 mm ²

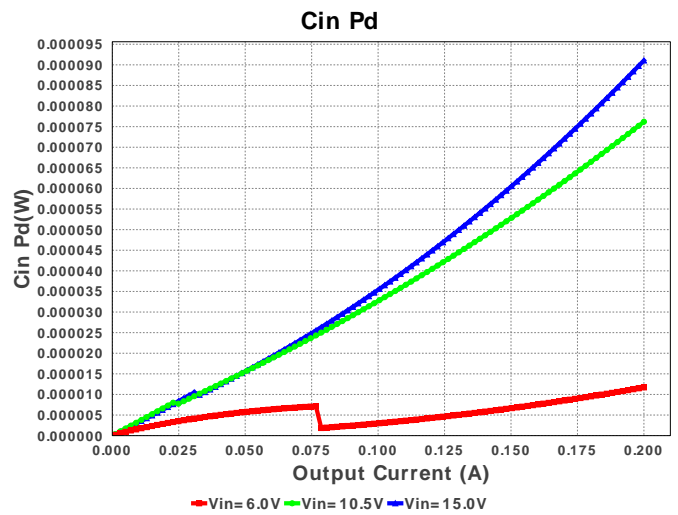
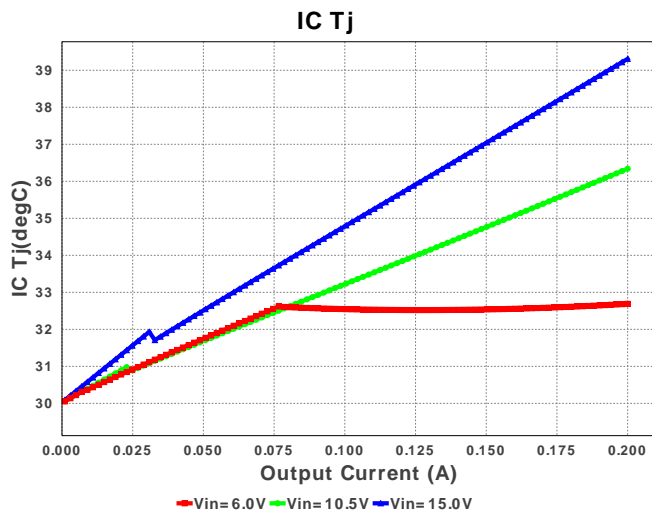
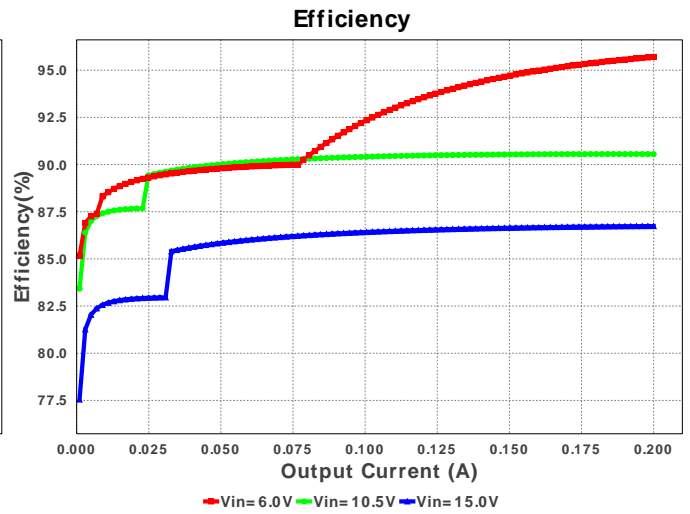
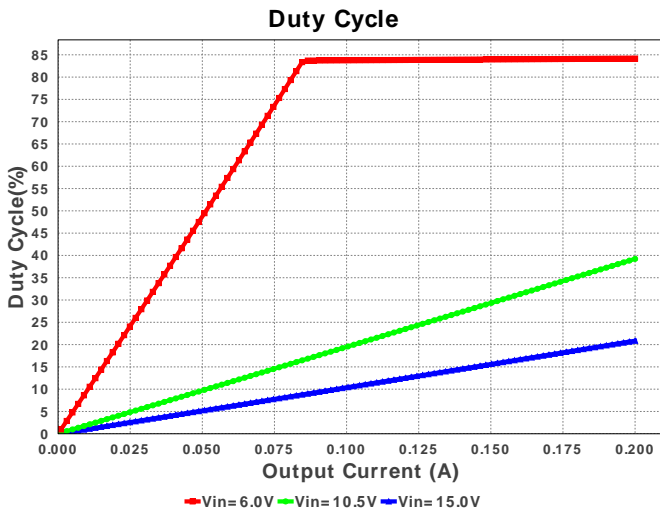
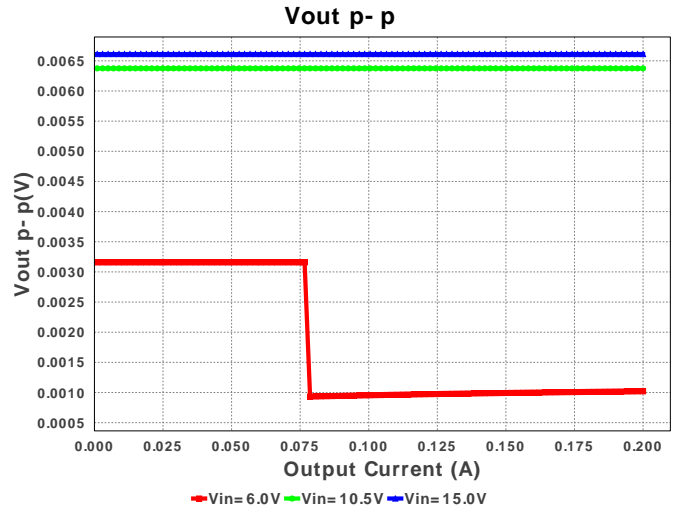
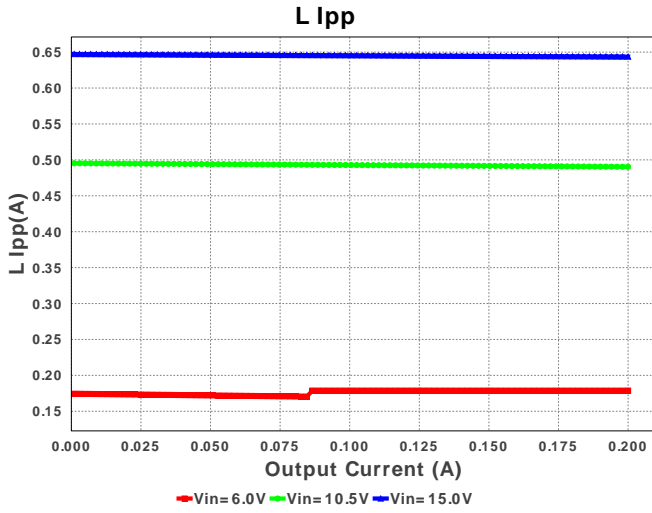
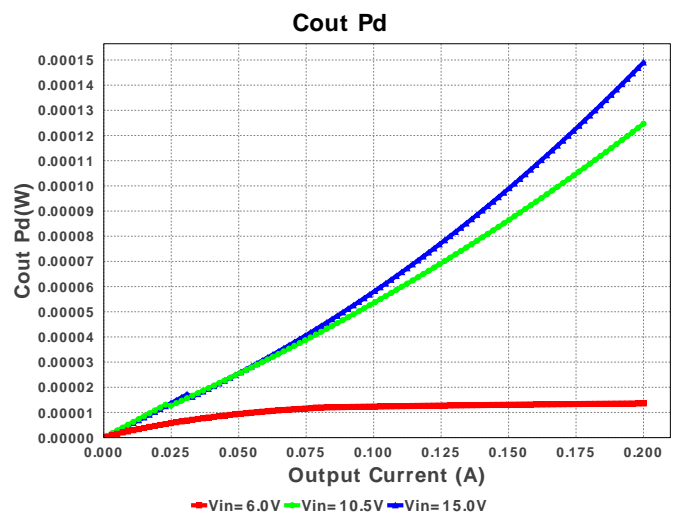
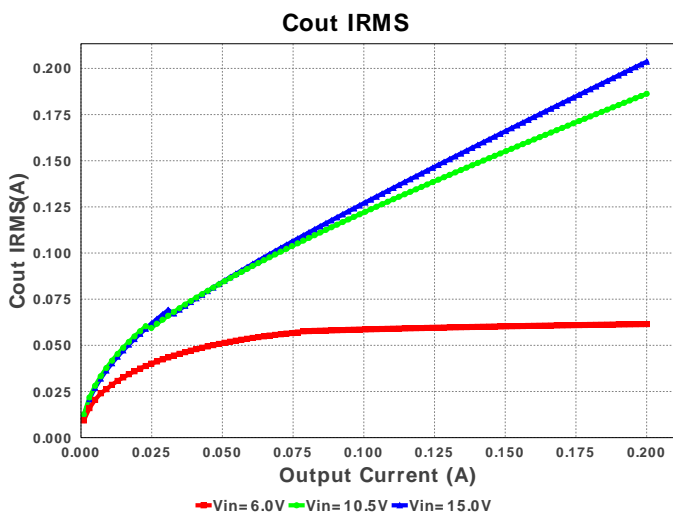
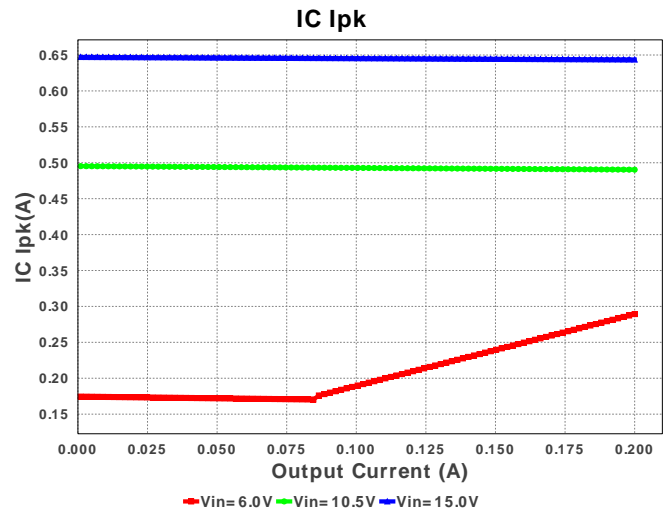
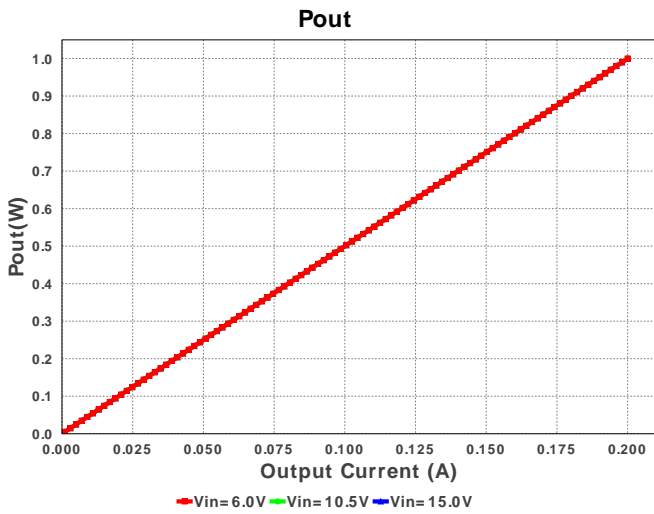
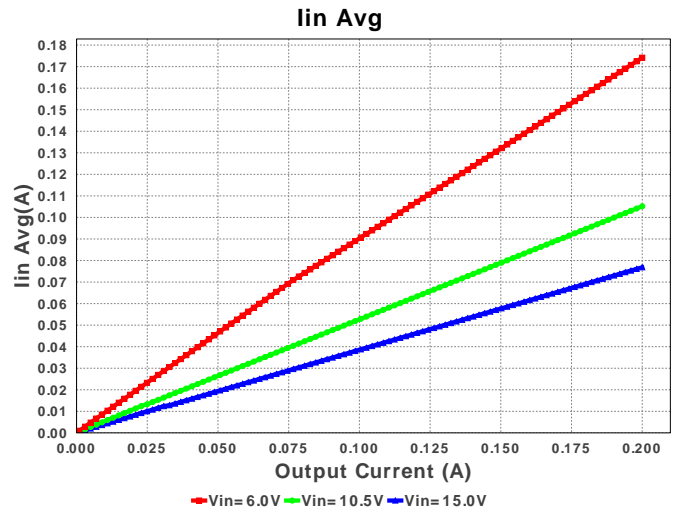
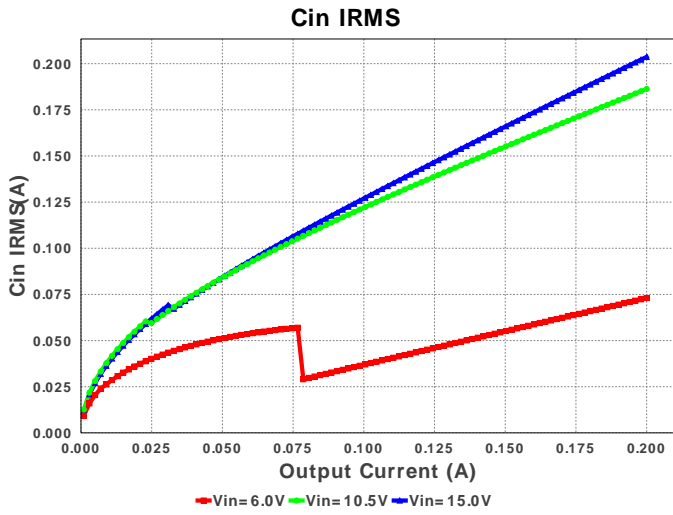

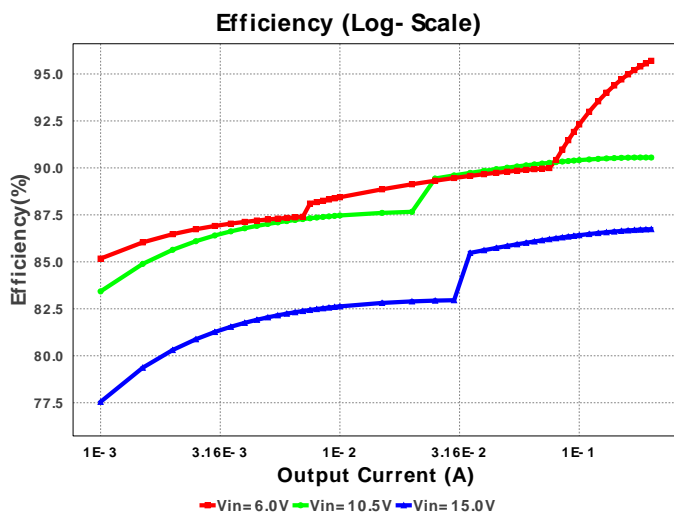
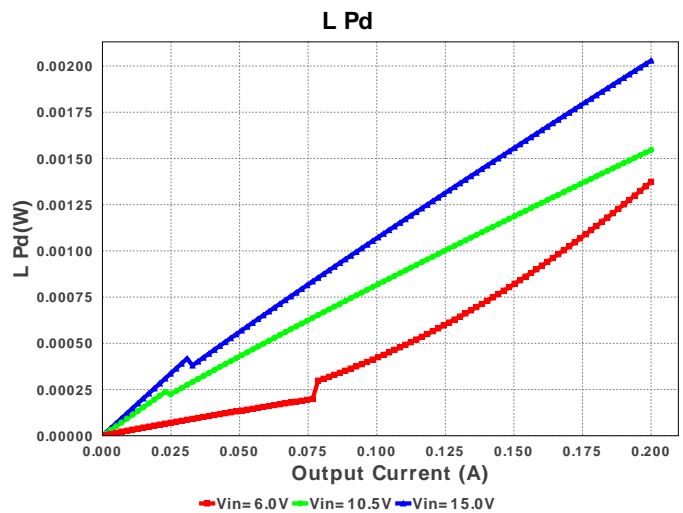
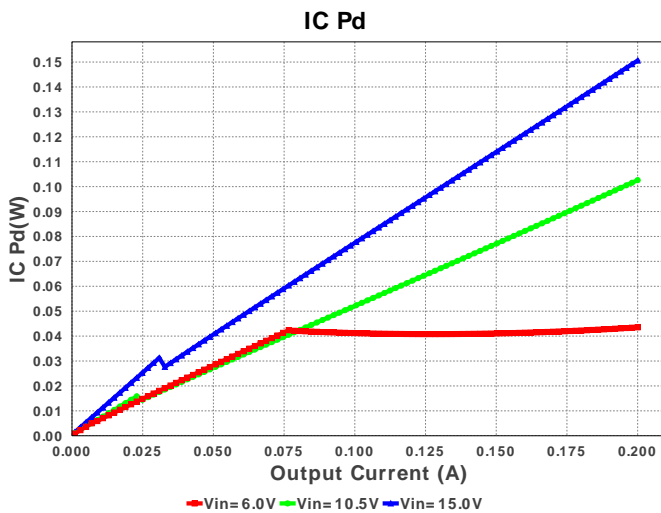
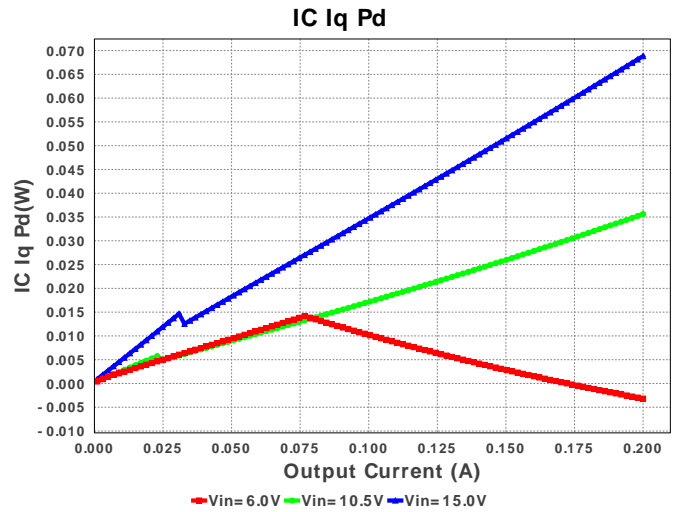
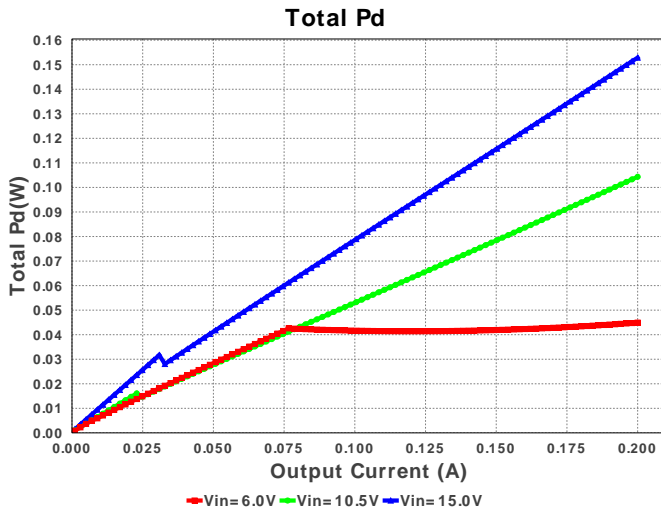



Operating Values

#	Name	Value	Category	Description
1.	Cin IRMS	203.653 mA	Current	Input capacitor RMS ripple current
2.	Cout IRMS	203.653 mA	Current	Output capacitor RMS ripple current
3.	IC Ipk	643.703 mA	Current	Peak switch current in IC
4.	Iin Avg	76.859 mA	Current	Average input current
5.	L Ipp	643.7 mA	Current	Peak-to-peak inductor ripple current
6.	BOM Count	7	General	Total Design BOM count
7.	FootPrint	108.0 mm ²	General	Total Foot Print Area of BOM components
8.	Frequency	1.452 MHz	General	Switching frequency
9.	Mode	DCM	General	Conduction Mode
10.	Pout	1.0 W	General	Total output power
11.	Total BOM	\$1.29	General	Total BOM Cost

#	Name	Value	Category	Description
12.	Vout OP	5.0 V	Op_Point	Operational Output Voltage
13.	Duty Cycle	20.864 %	Op_point	Duty cycle
14.	Efficiency	86.739 %	Op_point	Steady state efficiency
15.	IC Tj	39.308 degC	Op_point	IC junction temperature
16.	ICThetaJA	61.8 degC/W	Op_point	IC junction-to-ambient thermal resistance
17.	IOUT_OP	200.0 mA	Op_point	Iout operating point
18.	VIN_OP	15.0 V	Op_point	Vin operating point
19.	Vout p-p	6.612 mV	Op_point	Peak-to-peak output ripple voltage
20.	Cin Pd	91.064 µW	Power	Input capacitor power dissipation
21.	Cout Pd	149.017 µW	Power	Output capacitor power dissipation
22.	IC Iq Pd	68.836 mW	Power	IC Iq Pd
23.	IC Pd	150.617 mW	Power	IC power dissipation
24.	L Pd	2.029 mW	Power	Inductor power dissipation
25.	Total Pd	152.884 mW	Power	Total Power Dissipation

Design Inputs

#	Name	Value	Description
1.	Iout	200.0 m	Maximum Output Current
2.	VinMax	15.0	Maximum input voltage
3.	VinMin	6.0	Minimum input voltage
4.	Vout	5.0	Output Voltage
5.	base_pn	TPS62163	Base Product Number
6.	source	DC	Input Source Type
7.	Ta	30.0	Ambient temperature

Design Assistance

1. Feature Highlights: DCS-Control(TM) Architecture with upto 1A output current, 3V to 17V Input Voltage Range, 5V Fixed Output voltage, Seamless Power Save Mode for Light Load Efficiency, Power Good Output, 100% Duty Cycle mode, Short Circuit Protection, Thermal Shutdown

2. **TPS62163** Product Folder : <http://www.ti.com/product/TPS62163> : contains the data sheet and other resources.

Texas Instruments' WEBENCH simulation tools attempt to recreate the performance of a substantially equivalent physical implementation of the design. Simulations are created using Texas Instruments' published specifications as well as the published specifications of other device manufacturers. While Texas Instruments does update this information periodically, this information may not be current at the time the simulation is built. Texas Instruments does not warrant the accuracy or completeness of the specifications or any information contained therein. Texas Instruments does not warrant that any designs or recommended parts will meet the specifications you entered, will be suitable for your application or fit for any particular purpose, or will operate as shown in the simulation in a physical implementation. Texas Instruments does not warrant that the designs are production worthy.

You should completely validate and test your design implementation to confirm the system functionality for your application prior to production.

Use of Texas Instruments' WEBENCH simulation tools is subject to [Texas Instruments' Site Terms and Conditions of Use](#). Prototype boards based on WEBENCH created designs are provided AS IS without warranty of any kind for evaluation and testing purposes and are subject to the terms of the [Evaluation License Agreement](#).